



Primary Regulators

► Series 5700HP



► Series 5700HP:

High Performance

- New interlocking seat and diaphragm
- Integral safety
- Self relieving diaphragm
- Service friendly
- Tank and wall mount
- Wall mount available with high pressure hose lengths of 3', 6' and 9'
- Provides up to 9 SCFM (250 SLPM) with 15 psi. pressure drop





Primary Regulators

► Series 5700HP



► Specifications - Regulator:

Test Pressure:	6600 psig (455.17 bar.)
Maximum Inlet Pressure:	3300 psig (227.59 bar.)
Operating Range:	0-130 psig (0-8.97 bar.)
Temperature Range:	-40°F / +200°F (-40°C / 93°C)
Safety:	Preset 130 psig (8.97 bar.)
Mounting:	Wall or Bottle
HP Ports:	1/4" FPT - Left
LP Ports:	1/4" FPT - Right

Side View

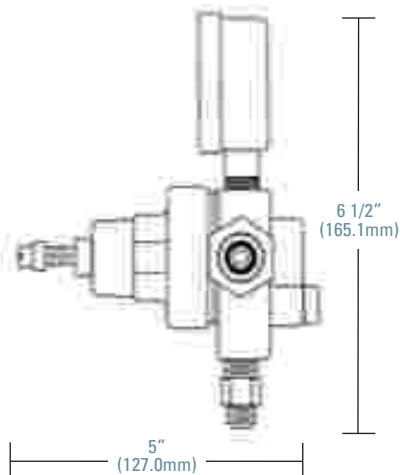

Front View

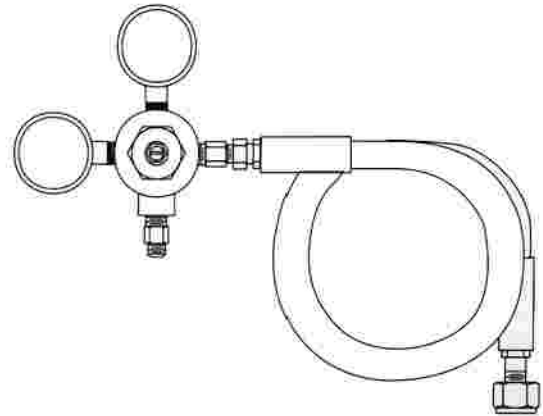
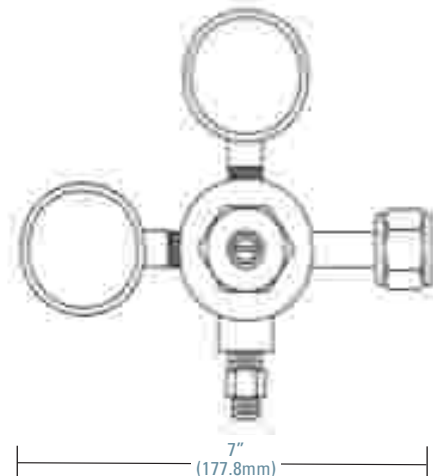

High Pressure Hose Assemblies are available for Wall Mount configurations in 3 ft (.91m), 6 ft (1.82m) and 9 ft (2.74m) lengths

► Specifications - Pressure Hose:

Burst Pressure:	14,000 psig (965.52 bar.)
Maximum Working Pressure:	2,700 psig (186.21 bar.)
Inlet:	CO ₂ (F) Swivel
Outlet:	1/4" SAE (F)
Bend Limiter:	Vinyl