



For Gas Operated BIB Pumps

- 3 gallon stainless steel tank
- Drives three or more pumps simultaneously
- Mount on wall, shelf or BIB rack
- Complete with regulator
- 100 psi continuous duty
- Rubber mount for quiet operation
- Requires power source 110v



Model CB-100W
(with optional Auto Drain)





14-0002-00 AIR CENTER WITH AUTO DRAIN

PARTS BREAKDOWN

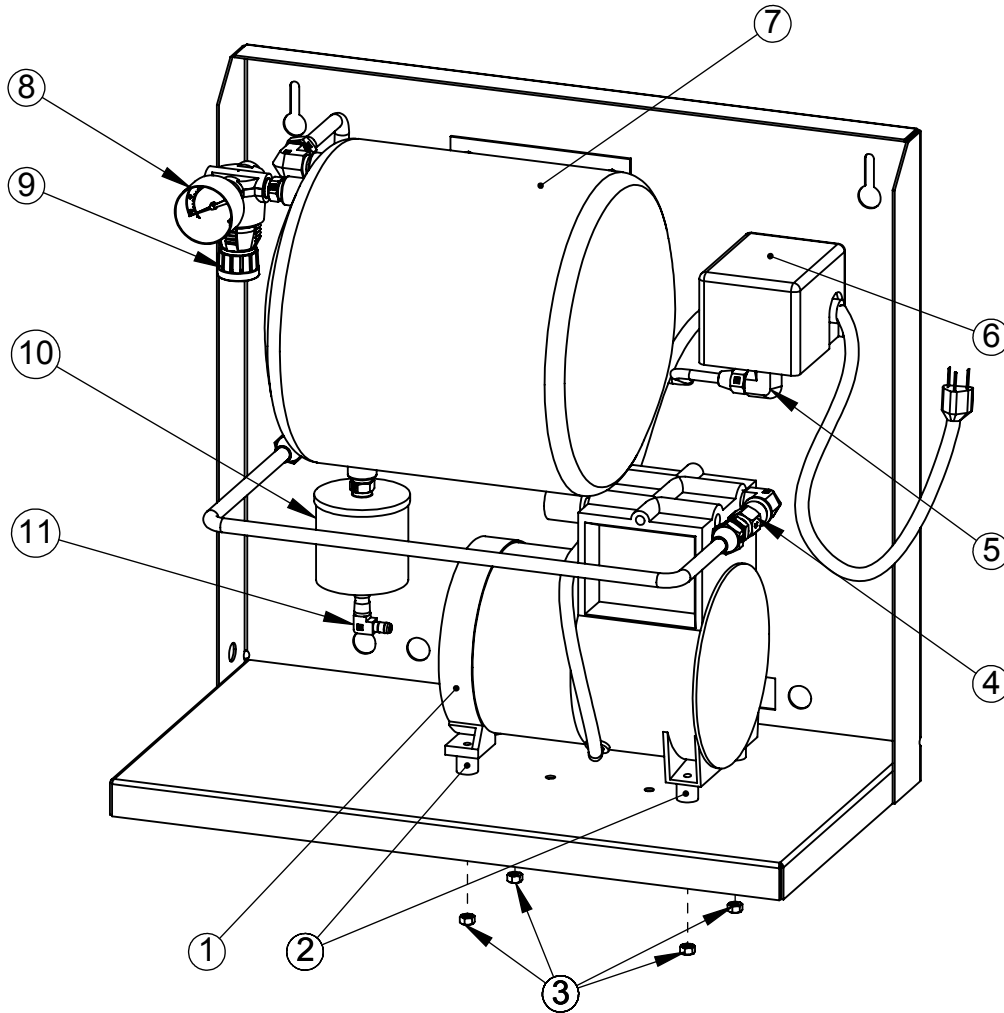

<u>ITEM NO:</u>	<u>PART NO:</u>	<u>DESCRIPTION:</u>
1	14-0010-00	COMPRESSOR .25 HP
2	14-0030-00	FOOT, VIBRATION MNT
3	06-2035-00	NUT, 8-32 KEPS ZP
4	14-0023-00	VALVE, CHECK
5	14-0022-00	ELBOW, FEMALE
6	14-0029-00	SWITCH, PRESSURE
7	14-0006-00	TANK, S.S. 3 GAL.
8	14-0028-00	GAUGE #160
9	14-0027-00	REGULATOR AIR
10	14-0031-00	DRAIN, AUTO 06 DIA
11	14-0021-00	ELBOW, MALE
12 (NOT SHOWN)	14-0032-00	KIT, SEALS FOR COMPRESSOR

REV A, 12-2010